

AIRSA

Pol. Ind. La Gavarra
Ronda Font Grossa, 1-3
Apdo. 23 · 08540 Centelles (Barcelona).

Tel.: (34) 93 881 38 00
Fax: (34) 93 881 38 02

info1@airsal.com
www.airsal.com



AIRSA
2015 The power of engine

index

Marchas
Boîtes à vitesses
Gear bike **Pag. 5 - 10**

ScooterAGUA
Liquide
ScooterLC **Pag. 13 - 18**

ScooterAGUA
Liquide **RACING X TREM**
ScooterLC **Pag. 21 - 24**

Scooter aire
Scooter à air
Scooter air cooled **Pag. 27 - 40**

Ciclomotor automático
Ciclomoteur
Mopeds **Pag. 43 - 50**

Cilindro de hierro
Iron cylinder
Cylindre en fonte **Pag. 53 - 56**

Cigüeñales
Vilebrequins
Crankshaft **Pag. 59 - 62**

Kit variador / Kit engranajes
Kit variateur / Kit engrenajes
Variator kit / Gears kit **Pag. 65 - 66**

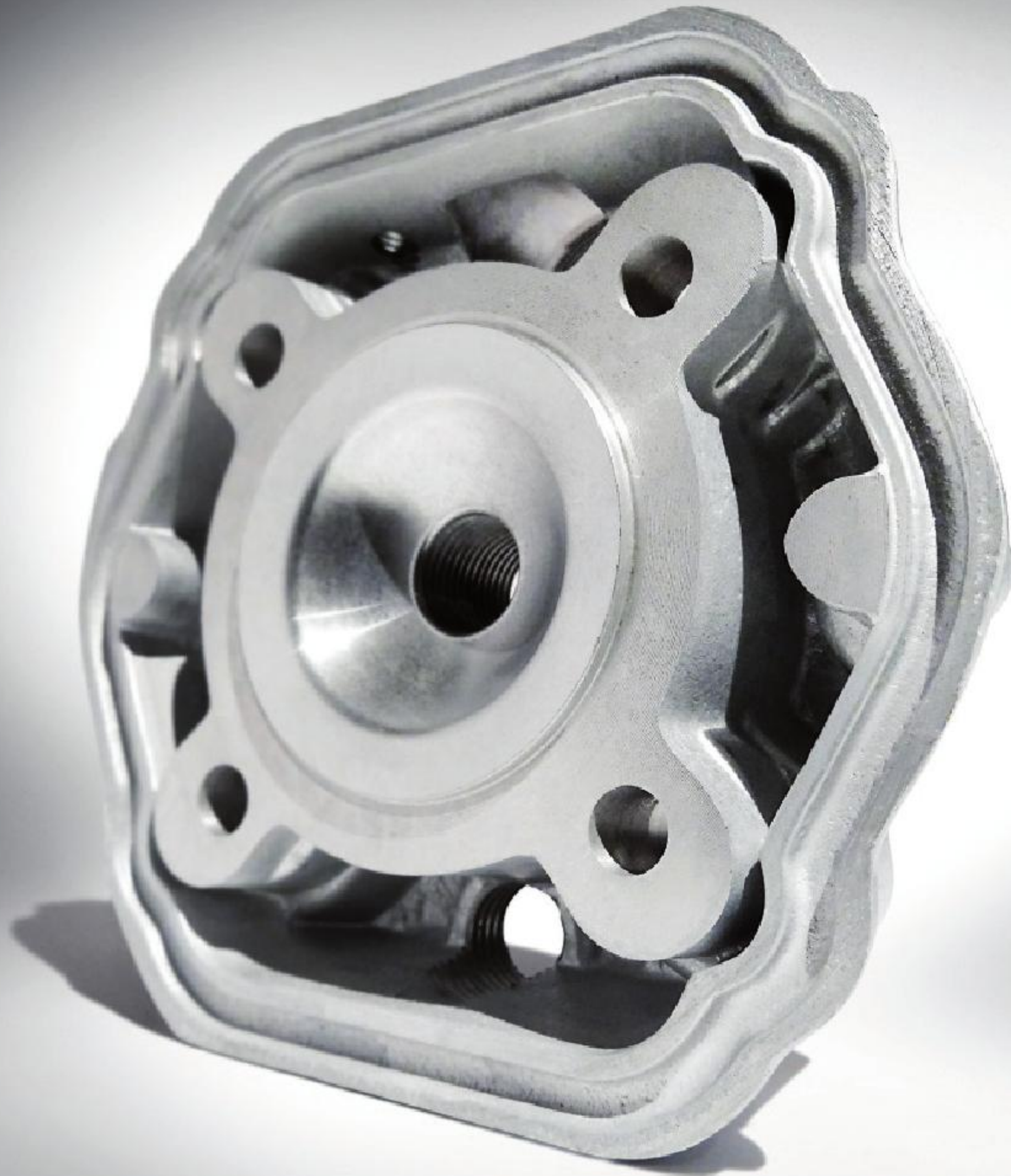

Marchas
Boites à vitesses
Gear bike



MOD. ADAPTABLE

APRILIA Alle 50, Extrema, Red rose, RS 50, RX 50.
MBK X Limit, X Power.
MINARELLI AM 345/6, AM 6 EU1.
MOTORHISPANIA Furia 50, Racing RX 50, Supermotard.
PEUGEOT Supermotard, Trail, XP6, XR6.
RIEJU MRK, RS1, RR6 50, SMX.
SHERCO HRD Enduro, Supermotard.
YAMAHA DT 50 Supermotard, Thunderkit, TZR 50.

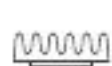

	Ø 40,3	49 cm ³	011313403	041313403	061313403	111313403	141313403
	Ø 48	70,5 cm ³	01131448	04131448	06131448	11131448	14131448
TECH PISTON	Ø 40,3	49 cm ³	011332403	041332403	061332403	111332403	141332403
TECH PISTON	Ø 48	70,5 cm ³	01133348	04133348	06133348	11133348	14133348
TECH PISTON	Ø 50	76,6 cm ³	01134950	04134950	06134950	11134950	14134950
	Ø 50	76,6 cm ³	01135850	04135850	06135850	11135850	14135850



MOD. ADAPTABLE

DERBI GPR 75.



	Ø 48	75 cm ³	01081848	04081848	06081848	11081848	14081848
--	------	--------------------	----------	----------	----------	----------	----------

Cilindro de aluminio con recubrimiento de níquel silicio.
 Cylindre en aluminium et revêtement de nickel carbure de silice.
 Aluminium cylinder with nickel silicon carbide plating.



MOD. ADAPTABLE

BULTACO Astro, Lobito.
DERBI DRD, GPR Racing, R Racer, Senda 50, SM Supermotard.
GILERA GSM, Zulú.



	Ø 39,9	50 cm ³	010814399	040814399	060814399	110814399	140814399
	Ø 48	72,4 cm ³	01081548	04081548	06081548	11081548	14081548
TECH PISTON	Ø 39,9	50 cm ³	010832399	040832399	060832399	110832399	140832399
TECH PISTON	Ø 48	72,4 cm ³	01083448	04083448	06083448	11083448	14083448
TECH PISTON	Ø 50	78,5 cm ³	01083750	04083750	06083750	11083750	14083750
	Ø 50	76,6 cm ³	01085850	04085850	06085850	11085850	14085850



MOD. ADAPTABLE

HONDA MB 50, MT 50.



	Ø 45	65,7 cm ³	02040845	06040845	11040845	14040845
--	------	----------------------	----------	----------	----------	----------



MOD. ADAPTABLE

SUZUKI TS 50 X.



MOD. ADAPTABLE

CPI Supermoto, SMX, Supercross.

Ø 47	68 cm ³						
		02050147	06050147	11050147	14050147		

Ø 40	49,2 cm ³	01300940	04300940	06300940	11300940	14300940	
Ø 50	76,9 cm ³	01301150	04301150	06301150	11301150	14301150	
TECH PISTON Ø 50	76,9 cm ³	01301050	04301050	06301050	11301050	14301050	

7

AIRSAI

Cilindro de aluminio con recubrimiento de níquel silicio.
Cylindre en aluminium et revêtement de nickel carbure de silice.
Aluminium cylinder with nickel silicon carbide plating.

8

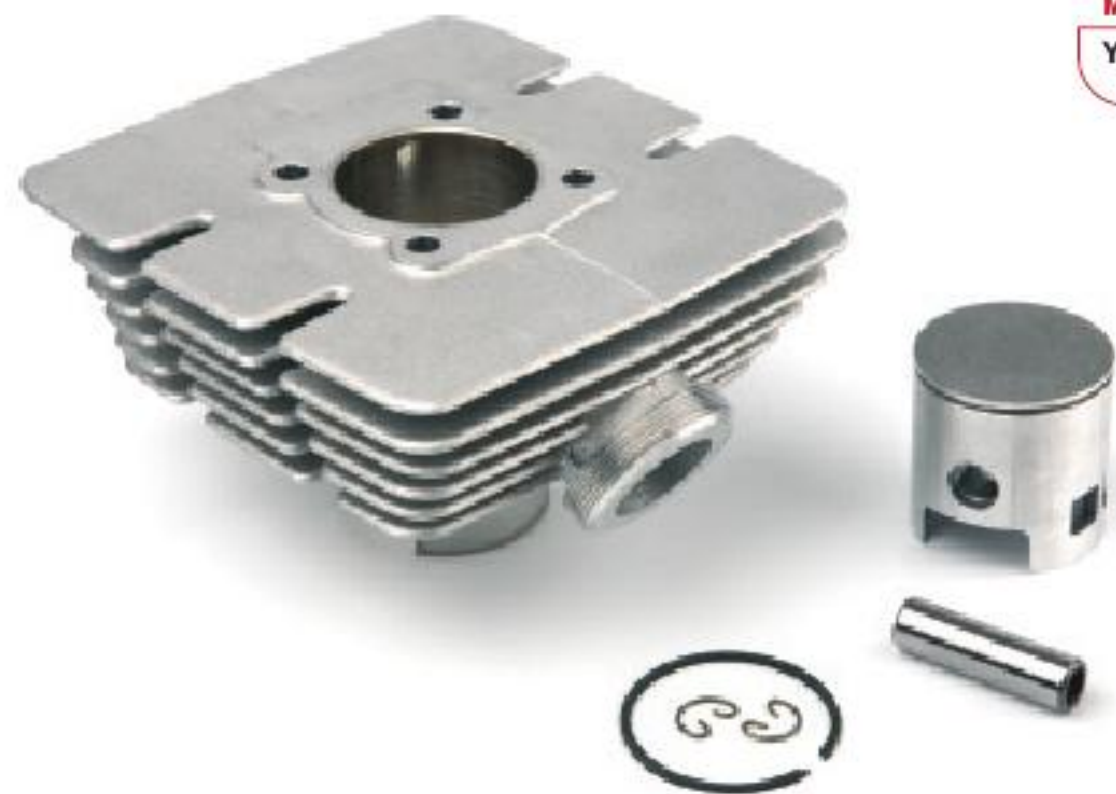

MOD. ADAPTABLE

YAMAHA DT 50, RD 50.



MOD. ADAPTABLE

SUZUKI RMX 50.

Ø 45	62,4 cm ³						
		02120345	06120345	11120345	14120345		

Ø 41	49,4 cm ³	02051541	06051541	11051541	14051541		
Ø 48	69,5 cm ³	02051648	06051648	11051648	14051648		



MOD. ADAPTABLE

ENGINE PIAGGIO

DERBI Mod. 2006 SENDA, SM, DRD, PRO,
SM, DRD Racin, Euro3.

GILERA RCR, SMT.

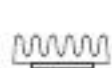

	Ø 39,9	50 cm ³	010840399	020840399	040840399	060840399	110840399	140840399
TECH PISTON	Ø 39,9	50 cm ³	010841399	020841399	040841399	060841399	110841399	140841399
	Ø 48	72,4 cm ³	01084248		04084248	06084248	11084248	14084248
TECH PISTON	Ø 50	78,5 cm ³	01084350		04084350	06084350	11084350	14084350
	Ø 50	76,6 cm ³	01085950		04085950	06085950	11085950	14085950



ScooterAGUA
Liquide
ScooterLC



MOD. ADAPTABLE

APRILIA Area, Gulliver, Ralli LC, Sonic, SR 50, Stealth LC.
BENELLI 491 Sport Racing, K2 LC.
BETA ARK LC, Eikon 50.
ITALJET Dragster.
MALAGUTI F12, F15, Firefox, Phantom LC.
MBK Nitro 50.
MINARELLI Horizontal.
RIEJU First 50 LC.
YAMAHA Aerox 50.



	Ø 40	49,2 cm ³	01071140	04071140	06071140	11071140	14071140
	Ø 47,6	69,7 cm ³	010713476	040713476	060713476	110713476	140713476
TECH PISTON	Ø 40	49,2 cm ³	01072540	04072540	06072540	11072540	14072540
TECH PISTON	Ø 47,6	69,7 cm ³	010726476	040726476	060726476	110726476	140726476



MOD. ADAPTABLE

APRILIA Grigio, Haranda, Hot Red, Replica SR, SR 2000R.
ATALA Hacker 50 LC, Skeggia 50 LC.
MORINI AH50L.
SUZUKI AY50LC, Katana LC.



	Ø 41	49,4 cm ³	01090341	04090341	06090341	11090341	14090341
	Ø 47,6	69,5 cm ³	010904476	040904476	060904476	110904476	140904476
TECH PISTON	Ø 47,6	69,5 cm ³	010905476	040905476	060905476	110905476	140905476

Cilindro de aluminio con recubrimiento de níquel silicio.
 Cylindre en aluminium et revêtement de nickel carbure de silice.
 Aluminium cylinder with nickel silicon carbide plating.



MOD. ADAPTABLE

DERBI GP1.
GILERA Runner 50.
PIAGGIO Extrem, NRG, NRG Mc2, NTT, Quartz, Zip, Zip Sp2000.



	Ø 40	49,2 cm ³	01061940	04061940	06061940	11061940	14061940
	Ø 47,6	69,7 cm ³	010621476	040621476	060621476	110621476	140621476
TECH PISTON	Ø 40	49,2 cm ³	01062940	04062940	06062940	11062940	14062940
TECH PISTON	Ø 47,6	69,7 cm ³	010630476	040630476	060630476	110630476	140630476



MOD. ADAPTABLE

PEUGEOT Speedfight 50 LC, X Race.



	Ø 40	49,4 cm ³	01023040	04023040	06023040	11023040	14023040
	Ø 47,6	69,5 cm ³	010231476	040231476	060231476	110231476	140231476
TECH PISTON	Ø 40	49,4 cm ³	01024240	04024240	06024240	11024240	14024240
TECH PISTON	Ø 47,6	69,5 cm ³	010243476	040243476	060243476	110243476	140243476



MOD. ADAPTABLE
KYMCO Bet&Win 50, Dink 50 LC, Super 9 50.



MOD. ADAPTABLE
PEUGEOT Ludix Blaster, Speedfight 3.



Ø 39	49,5 cm ³	01160739	04160739	06160739	11160739	14160739
Ø 47,6	73,8 cm ³	011608476	041608476	061608476	111608476	141608476

Ø 40	49,2 cm ³	01025440	02025440	04025440	06025440	11025440	14025440
76 Ø 40	49,2 cm ³	01026340	02026340	04026340	06026340	11026340	14026340
Ø 47,6	69,7 cm ³	010255476	020255476	040255476	060255476	110255476	140255476



MOD. ADAPTABLE
CPI GTR 50.



MOD. ADAPTABLE
SYM HD 125 EVO, HD 125.

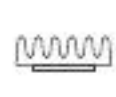

Ø 40	49,2 cm ³	01300540	04300540	06300540	11300540	14300540
Ø 47,6	69,7 cm ³	013006476	043006476	063006476	113006476	143006476

Ø 64	156,9 cm ³	02370164	06370164	11370164	14370164
------	-----------------------	----------	----------	----------	----------



MOD. ADAPTABLE

HONDA 125 4TLC, Phantheon 125 4T, S-Wing4T INJ, SH125 I, Dylan 125, PS 125, SH 125 Scoopy, SH 125 I.
KEEWAY Outlook (QJ153MJ-2) 125 4T.
MALAGUTI Blog (03) 125 4T LC.



MOD. ADAPTABLE

YAMAHA X MAX 125, City 125, WR 125 R, WR 125 X, YZF 125 R.
MBK Citylinder.

Ø	Stroke / Carrera	cm ³							
52,4	57,8	124,6				020462524	060462524	110462524	140462524
58	57,8	152,7				02046358	06046358	11046358	14046358

Ø	Stroke / Carrera	cm ³							
52	58,6	124,6				02125852	06125852	11125852	14125852
76 52	52	124,6				02125952	06125952	11125952	14125952



MOD. ADAPTABLE

HONDA 150 4T, Phantheon 150 4T LC, S-Wing4TLC, SH150 I, Dylan 150 4T, PS 150 4T LC, SH Scoopy 150 4T.
KEEWAY Outlook (QJ158MJ) 150 4T.



MOD. ADAPTABLE

SUZUKI Burgman 125 LC.

Ø	Stroke / Carrera	cm ³							
58	57,8	152,7				02046458	06046458	11046458	14046458
61	57,8	168,9				02046561	06046561	11046561	14046561

Ø	Stroke / Carrera	cm ³							
57	124,5					02052357	06052357	11052357	14052357

RACING **X**TREM



ScooterAGUA
Liquide
ScooterLC



MOD. ADAPTABLE

APRILIA Alle 50, Extrema, Red rose, RS 50, RX 50.
MBK X Limit, X Power.
MINARELLI AM 345/6, AM 6 EU1.
MOTORHISPANIA Furia 50, Racing RX 50, Supermotard.
PEUGEOT Supermotard, Trail, XP6, XR6.
RIEJU MRK, RS1, RR6 50, SMX.
SHERCO HRD Enduro, Supermotard.
YAMAHA DT 50 Supermotard, Thunderkit, TZR 50.



MOD. ADAPTABLE

ENGINE PIAGGIO
DERBI Mod. 2006 SENDA, SM, DRD, PRO, SM, DRD Racing.
GILERA RCR, SMT.

	Ø	Stroke / Carrera	cm ³						Ø	Stroke / Carrera	cm ³						
TECH PISTON	50	45	88,3	01137550	04137550	06137550	11137550	14137550	TECH PISTON	50	45	88,3	01087550	04087550	06087550	11087550	14087550
TECH PISTON	50	40	78,5	01133150	04133150	06133150	11133150	14133150	TECH PISTON	50	40	78,5	010810050	040810050	060810050	110810050	140810050

Cilindro de aluminio con recubrimiento de níquel silicio.
 Cylindre en aluminium et revêtement de nickel carbure de silice.
 Aluminium cylinder with nickel silicon carbide plating.



MOD. ADAPTABLE

BULTACO Astro, Lobito.
DERBI DRD, GPR Racing, R Racer, Senda 50, SM Supermotard.
GILERA GSM, Zulú.



MOD. ADAPTABLE

APRILIA Area, Gulliver, Ralli LC, Sonic, SR 50, Stealth LC.
BENELLI 491 Sport Racing, K2 LC.
BETA ARK LC, Eikon 50.
ITALJET Dragster.
MALAGUTI F12, F15, Firefox, Phantom LC.
MBK Nitro 50.
RIEJU First 50 LC.
YAMAHA Aerox 50.

	Ø	Stroke / Carrera	cm ³						Pin / Bul.	Ø	Stroke / Carrera	cm ³						
TECH PISTON	50	45	88,3	01087650	04087650	06087650	11087650	14087650	TECH PISTON	12	50	45	88,3	01073350	04073350	06073350	11073350	14073350
TECH PISTON	50	40	78,5	01089950	04089950	06089950	11089950	14089950	TECH PISTON	12	50	39,2	77,1	01073450	04073450	06073450	11073450	14073450
									TECH PISTON	12	47,6	45	80,07	010732476	040732476	060732476	110732476	140732476
									TECH PISTON	12	47,6	39,2	69,6	010735476	040735476	060735476	110735476	140735476

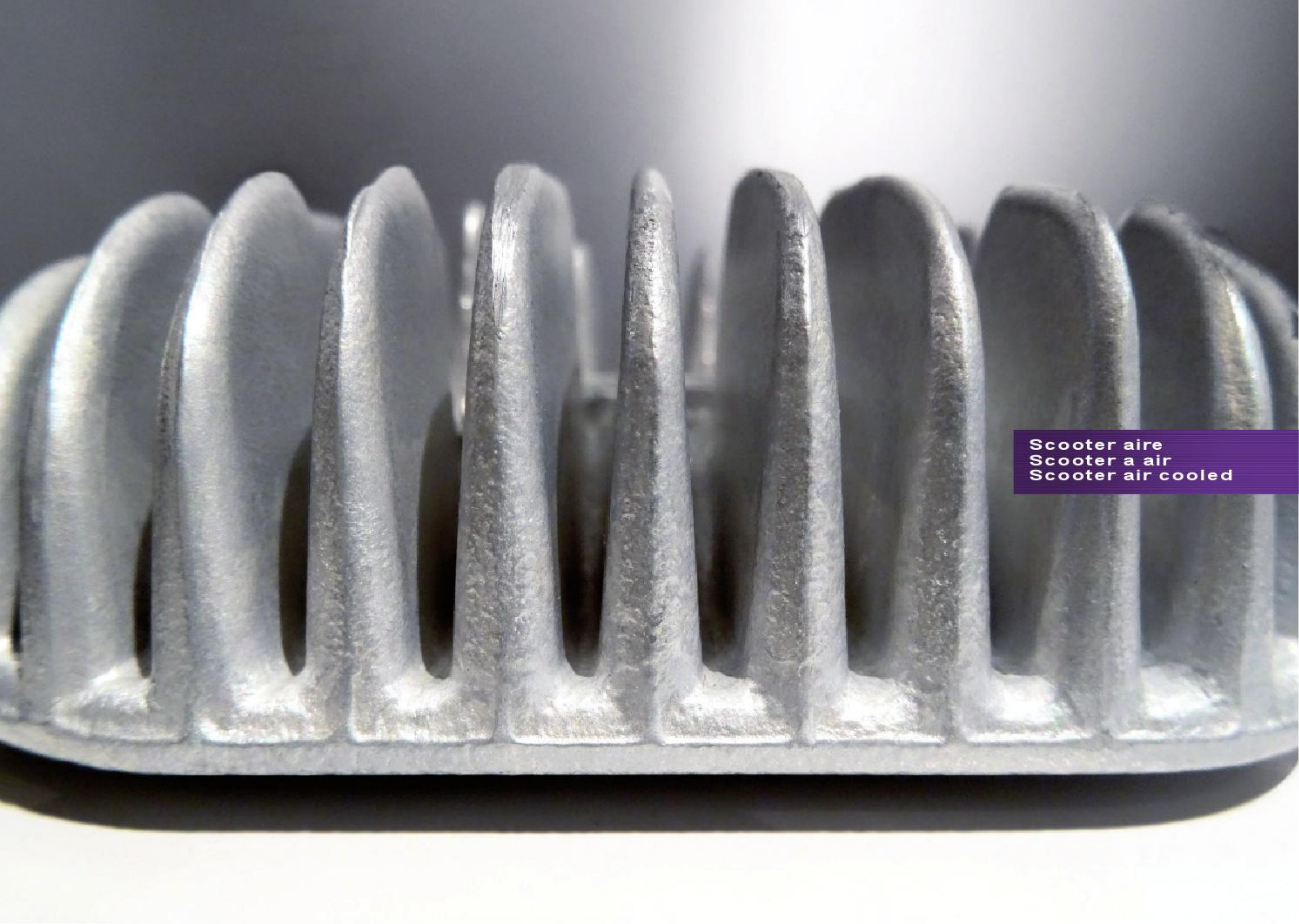

Scooter aire
Scooter a air
Scooter air cooled



MOD. ADAPTABLE

APRILIA Gulliver, Rally, Scarabeo, Sonic, SR94, SR www.
ATALA Corosello.
BENELLI 491 GT, K2 air, Namur, Pepe.
BETA Ark, Chrono, Tempo, Quadra.
BSV AX, GZ.
CPI Euro 1, Hussar.
MALAGUTI Centro, Ciak, F10, F12, Phantom 50, Yesterday.
MBK Evolis, Fizz, Flipper, Forte, Hot Champ, Ovetto, Sorriso.
MINARELLI CY50, Horizontal.
MOTRON Syncro, Thunder S.
PGO Big Max.
RIEJU First 50, Windi.
YAMAHA Axis, Breeze, Jog 50, Jag Z, Neos, Why, Zest.



MOD. ADAPTABLE

PEUGEOT Buxi SV Geo, Elyseo, Speedaker, Speedfight 2, Trekker, Vivacity, Zenit.

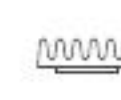
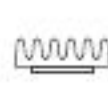

	Ø 40	49,2 cm ³	01130940	02130940	04130940	06130940	11130940	14130940
	Ø 46	65 cm ³	01131046	02131046	04131046	06131046	11131046	14131046
76	Ø 40	49,2 cm ³	01131540	02131540	04131540	06131540	11131540	14131540
76	Ø 47,6	69,7 cm ³	011316476	021316476	041316476	061316476	111316476	141316476
TECH PISTON	Ø 40	49,2 cm ³	01133640	02133640	04133640	06133640	11133640	14133640
TECH PISTON	Ø 47,6	69,7 cm ³	011337476	021337476	041337476	061337476	111337476	141337476

	Ø 40	49,2 cm ³	01021940	02021940	04021940	06021940	11021940	14021940
	Ø 46	65 cm ³	01022046	02022046	04022046	06022046	11022046	14022046
76	Ø 40	49,2 cm ³	01022340	02022340	04022340	06022340	11022340	14022340
76	Ø 47,6	69,7 cm ³	010224476	020224476	040224476	060224476	110224476	140224476
TECH PISTON	Ø 40	49,2 cm ³	01024040	02024040	04024040	06024040	11024040	14024040
TECH PISTON	Ø 47,6	69,7 cm ³	010241476	020241476	040241476	060241476	110241476	140241476

Cilindro de aluminio con recubrimiento de níquel silicio.
 Cylindre en aluminium et revêtement de nickel carbure de silice.
 Aluminium cylinder with nickel silicon carbide plating.



MOD. ADAPTABLE

APRILIA Amico, Business, Gludman, LK, LX, Sport, SR.
ITALJET Ascot, Astra, Bazoka, Pista, Reporter.
LEM Flash, Ghibli, SS1, Tornado.
MBK Booster, Rocket, Sorriso, Stunt, Target.
MINARELLI CW50, Vertical.
YAMAHA BWS, CT50, CR50 Z, Slinder, SPY50, Zuma.



MOD. ADAPTABLE

GILERA Easy Moving, Stalker 50, Storm, Typhoon.
PIAGGIO Extrem, Free 50, Liberty, Sfera 50, Storm, Typhoon, Vespa ET2, Zip.

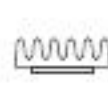

	Ø 40	49,2 cm ³	01131140	02131140	04131140	06131140	11131140	14131140
	Ø 46	65 cm ³	01131246	02131246	04131246	06131246	11131246	14131246
76	Ø 40	49,2 cm ³	01131740	02131740	04131740	06131740	11131740	14131740
76	Ø 47,6	69,7 cm ³	011318476	021318476	041318476	061318476	111318476	141318476
TECH PISTON	Ø 40	49,2 cm ³	01133440	02133440	04133440	06133440	11133440	14133440
TECH PISTON	Ø 47,6	69,7 cm ³	011335476	021335476	041335476	061335476	111335476	141335476

	Ø 40	49,2 cm ³	01061340	02061340	04061340	06061340	11061340	14061340
	Ø 46	65 cm ³	01061446	02061446	04061446	06061446	11061446	14061446
76	Ø 40	49,2 cm ³	01061640	02061640	04061640	06061640	11061640	14061640
76	Ø 47,6	69,7 cm ³	010617476	020617476	040617476	060617476	110617476	140617476
TECH PISTON	Ø 40	49,2 cm ³	01062740	02062740	04062740	06062740	11062740	14062740
TECH PISTON	Ø 47,6	69,7 cm ³	010628476	020628476	040628476	060628476	110628476	140628476



MOD. ADAPTABLE

HONDA Lead 50, SH 50.
PEUGEOT Metropolis, SC 50.



Ø 40 49,9 cm³
 Ø 46 65,3 cm³

02041840
 02041946

06041840
 06041946

11041840
 11041946

14041840
 14041946



MOD. ADAPTABLE

HONDA Dio 50, SP 50, SR 50, ST 50, ZX 50.



Ø 39 49,9 cm³
 Ø 46 69,4 cm³

02044039
 02044146

06044039
 06044146

11044039
 11044146

14044039
 14044146



MOD. ADAPTABLE

HONDA Vision NE 50.
PEUGEOT Rapido, ST 50.



Ø 41 49,4 cm³
 Ø 46 62,1 cm³

02042041
 02042146

06042041
 06042146

11042041
 11042146

14042041
 14042146



MOD. ADAPTABLE

HONDA PK 50 Wallaroo.



Ø 40 49,3 cm³
 Ø 46 65,3 cm³

02042240
 02042346

06042240
 06042346

11042240
 11042346

14042240
 14042346

MOD. ADAPTABLE

KYMCO BJW, Curio 50 CX, Curio CX
Sup., DJR, KB 50, R 12 Scout ZX, Sniper.

**MOD. ADAPTABLE**

CPI 2003 Euro 2: Pop corn, Jp 50, Oliver City, Oliver Sport.

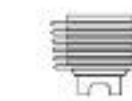

Ø 39 49,9 cm³
Ø 46 69,4 cm³

02160139
02160246

06160139
06160246

11160139
11160246

14160139
14160246

76 Ø 40 49,2 cm³
76 Ø 47,6 69,5 cm³

01300140
013002476

04300140
043002476

06300140
063002476

11300140
113002476

14300140
143002476

31

AIRSAL

Cilindro de aluminio con recubrimiento de níquel silicio.
Cylindre en aluminium et revêtement de nickel carbure de silice.
Aluminium cylinder with nickel silicon carbide plating.

32

MOD. ADAPTABLE

ATALA Byte AT10, EP 50, Hacker AT12.
DERBI Vamos.
ITALJET Torpedo, Velocifero.
SUZUKI Adress 50, AP, AY50, Katana, Sepia,
Street magic.

**MOD. ADAPTABLE**

PEUGEOT Ludix.



Ø 41 49,3 cm³
Ø 46 65 cm³

02050541
02050646

06050541
06050646

11050541
11050646

14050541
14050646

Ø 40 49,2 cm³
76 Ø 40 49,2 cm³
76 Ø 47,6 69,7 cm³

01025040
01025340
010251476

02025040
02025340
020251476

04025040
04025340
040251476

06025040
06025340
060251476

11025040
11025340
110251476

14025040
14025340
140251476



MOD. ADAPTABLE

- APRILIA** Gulliver, Rally, Scarabeo, SR50 www, 94, 95, 96, 97.
- ATALA** Carosello.
- BENELLI** 491 GT, K2, Naked 50, Pepe.
- BETA** Ark, Chrono, Quad.
- BSV** Ax, Jx, Gz.
- BOMBARDIER** DS 50.
- CPI** Husar 2002, Popkorn 2002.
- DINLI** Diamond back 50, Cobia 50, JP 50, Dino 50.
- E-TON** Viper 50.
- FACTORY** Helix 50, T-Rex 50, Tornado 50.
- KREIDLER** Easy Rider.
- KTM** K50.
- MALAGUTI** Centro SL, Ciak, F10, F12, F12 Phantom 2000.
- MBK** Equalis, Evolis, Fizz, Flipper, Ovetto 50, Sorriso 96.
- MOTRON** Sting, Syncro, Thunder.
- PGO** Big Max.
- POLARIS** Predator 50.
- YAMAHA** Axis Breeze, Jog, Jog Z, Vino, Why.



MOD. ADAPTABLE

- CPI** 2004 Euro 2: Pop corn, Jp 50, Oliver City, Oliver Sport.
- GENERIC** Xor 50, Ideo 50.
- KEEWAY** Hurricane, Flash, F-ACT, Matrix.

TECH PISTON	T6R	Ø 47,6	69,7 cm ³														
				011350476	021350476	041350476	061350476	111350476	141350476	T6	Ø 40	49,2 cm ³	01300340	04300340	06300340	11300340	14300340
										T6	Ø 47,6	69,5 cm ³	013004476	043004476	063004476	113004476	143004476

Cilindro de aluminio con recubrimiento de níquel silicio.
Cylindre en aluminium et revêtement de nickel carbure de silice.
Aluminium cylinder with nickel silicon carbide plating.



MOD. ADAPTABLE

- HYOSUNG** Prima, Rally.



MOD. ADAPTABLE

- ENGINE** 139QMB, GY6.
- ENGINE LIFAN** 1P139 QMB.
- BAOTIAN** BT49QT-2, BT49QT-7, BT50QT-9, BT50QT-11, Ecobike.
- DH HAOTIAN** HT50 QT8, HT50 QT7.
- YIYING** YY 50 QT.
- BENZHO** City Star50.
- JIN LUN** JL50QT.
- KREIDLER** Flory 50.
- KYMC** Agility 50, MMC 50, Filly 50, Vitality 50 4T, Nexxon 50, People 4T, Super 8, Yager GT.
- LIFAN** LF50QT-7, LF 50 QT4, LF 50 QT2, LF 50 QT15, LF 50 QT9F.
- MSK** Ecobike 50.
- PEUGEOT** V-Click.
- REX** Capriolo 50, Flory, RS450, RS500, Off limit 45, Paseo50, Torea50.
- RIEJU** Torea, Pacific.
- SACHS** 49er50, Bee.
- SANLI** TS50QT-4.
- QINGQI** QM50QT-6A.
- XINLING** TXM50.
- ZHONGYU** 50QT-5, ZY 50QT.
- ZONGSHEN** Wind 25/50, ZS50QT-4 50.
- VERUCCI** 50 4T.
- SCHWINN** Campus, Hope, Collegiate, Sport, Graduate.

		Ø 41	49,3 cm ³												
				02320141	06320141	11320141	14320141								
		Ø 46	62 cm ³	02320246	06320246	11320246	14320246								



MOD. ADAPTABLE

- ADLY** Supersonic 125, Thunderbike 125.
- BAOTIAN** BT125T, Rally.
- CPI** Oliver City 125, Aragon 125.
- DH HAOTIAN** HT125T.
- ENGINE** 152 QMI, GY6.
- ENGINE LIFAN** 1P152 QMI.
- JIN LUN** JL125T.
- KYMC**O People 125, Agility 125, Movie 125, Agility, City 125, Like 125.
- LINHAI** monarch LH125T.
- RIEJU** Pacific125.
- SUMCO** Maxi 125, Manga 125.
- SYM** Simply, Fiddle, Orbit 125.
- TGB** 303R 125, Delivery 125.
- YIYING** YY125T.
- XINLING** YY125T.
- ZHONGYU** ZY125.
- ZONGSHEN** ZS125T.



MOD. ADAPTABLE

- KEEWAY** 125, ARN 125, F ACT 125, Matrix125.



Ø 57,4 149,5 cm³

023502574

063502574

113502574

143502574

Ø 57,4 149,5 cm³

023601574

063601574

113601574

143601574

Cilindro de aluminio con recubrimiento de níquel silicio.
Cylindre en aluminium et revêtement de nickel carbure de silice.
Aluminium cylinder with nickel silicon carbide plating.

MOD. ADAPTABLE

- ENGINE** 157 QMJ, GY6.
- ENGINE LIFAN** 1P157 QMJ.
- HUATIAN** HT150T.
- LONCIN** QUAD ATV150.
- KYMC**O People150, Bet&Win.
- LINHAI** Aeolus Retro150.
- LIFAN** LF150T-7, LF150T-2B, LF150T-8, LF150T-6.



MOD. ADAPTABLE

- SYM** Euro MX 125, Euro MX 125 DD, VS 125.



Ø 60 163,4 cm³

02350360

06350360

11350360

14350360

Ø 60 163,4 cm³

02370260

06370260

11370260

14370260



MOD. ADAPTABLE

SYM MIO 50.



MOD. ADAPTABLE

PEUGEOT Elyseo 100, Speedfight 100, Vivacy 100, Looxor 100, Trekker 100, x-fight.

Ø 42	63 cm ³							Ø	Stroke / Carrera	cm ³						
		02370342	06370342	11370342	14370342	55	125	02026355			06026355	11026355	14026355			

Cilindro de aluminio con recubrimiento de níquel silicio.
Cylindre en aluminium et revêtement de nickel carbure de silice.
Aluminium cylinder with nickel silicon carbide plating.



MOD. ADAPTABLE

HONDA Bali 50, SGX Sky 50, SXR 50, SFX 50, SH 50, X8R 50.



MOD. ADAPTABLE

KYMCO Dink 50, Top Boy 50, Vitality 2T.

Ø	Stroke / Carrera	cm ³							Ø	Stroke / Carrera	cm ³							
39	41,4	49,4	02044539	06044539	11044539	14044539	Ø 39	49,5 cm ³	02160539	06160539	11160539	14160539	Ø 47,6	73,8 cm ³	021606476	061606476	111606476	141606476

MOD. ADAPTABLE

HONDA Yupy 90.



Ø 52 105,3 cm³



02043952

06043952

11043952

14043952

Cilindro de aluminio con recubrimiento de níquel silicio.
Cylindre en aluminium et revêtement de nickel carbure de silice.
Aluminium cylinder with nickel silicon carbide plating.

MOD. ADAPTABLE

APRILIA Scarabeo 100.

BENELLI K2 100.

ITALJET Millenium 100.

MBK Booster 100, Nitro 100, Oveto 100.

YAMAHA Bw's 100, Aerox 100, Neo's 100.



Ø 56 117,2 cm³



01126556

02126556

04126556

06126556

11126556

14126556



Ciclomotor automático
Ciclomoteur
Mopeds



MOD. ADAPTABLE

DERBI Variant Start.



Ø 39,9	50 cm ³	020808399	060808399	110808399	140808399
Ø 44	60,8 cm ³	02080244	06080244	11080244	14080244



MOD. ADAPTABLE

MBK AV-7, AV-87.



Ø 39	49,9 cm ³	02140239	06140239	11140239	14140239
Ø 45	66,5 cm ³	02140345	06140345	11140345	14140345

Cilindro de aluminio con recubrimiento de níquel silicio.
Cylindre en aluminium et revêtement de nickel carbure de silice.
Aluminium cylinder with nickel silicon carbide plating.



MOD. ADAPTABLE

GAC Mobilette Campera, Rural.
MBK Carre AV88.



Ø 39	49,9 cm ³	02140139	06140139	11140139	14140139
Ø 45	66,5 cm ³	02140445	06140445	11140445	14140445
Ø 47	72,5 cm ³	02140847	06140847	11140847	14140847



MOD. ADAPTABLE

MBK AV-10, AV-51.



Ø 39	49,9 cm ³	02140639	06140639	11140639	14140639
Ø 47	72,5 cm ³	02140547	06140547	11140547	14140547
76 Ø 39	49,9 cm ³	02140739	06140739	11140739	14140739
76 Ø 47	72,5 cm ³	02144847	06144847	11144847	14144847

MOD. ADAPTABLE

MBK FX 50 Agua, Mágnum, Racing, Rock.
YAMAHA Mágnum 50.



Ø 39 49,9 cm³
Ø 47 72,5 cm³

02141139
02141247

06141139
06141247

11141139
11141247

14141139
14141247

MOD. ADAPTABLE

PEUGEOT 103 XPLC Agua, Clip LC, RCXLC.



Ø 40 49,4 cm³
Ø 46 65,3 cm³

01021740
01021846

02021740
02021846

04021740
04021846

06021740
06021846

11021740
11021846

14021740
14021846

MOD. ADAPTABLE

PEUGEOT 103 T3, 104 T3 Brida.

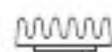

Ø 40 49,4 cm³
Ø 46 65,3 cm³
76 Ø 40 49,4 cm³
76 Ø 46 65,3 cm³

02020640
02020846
02020940
02022546

06020640
06020846
06020940
06022546

11020640
11020846
11020940
11022546

14020640
14020846
14020940
14022546

MOD. ADAPTABLE

PIAGGIO VESPA AL, ALX, NLX, Vespino T6.



Ø 38,4 49,8 cm³
Ø 43,5 64 cm³

020601384
020609435

060601384
060609435

110601384
110609435

140601384
140609435

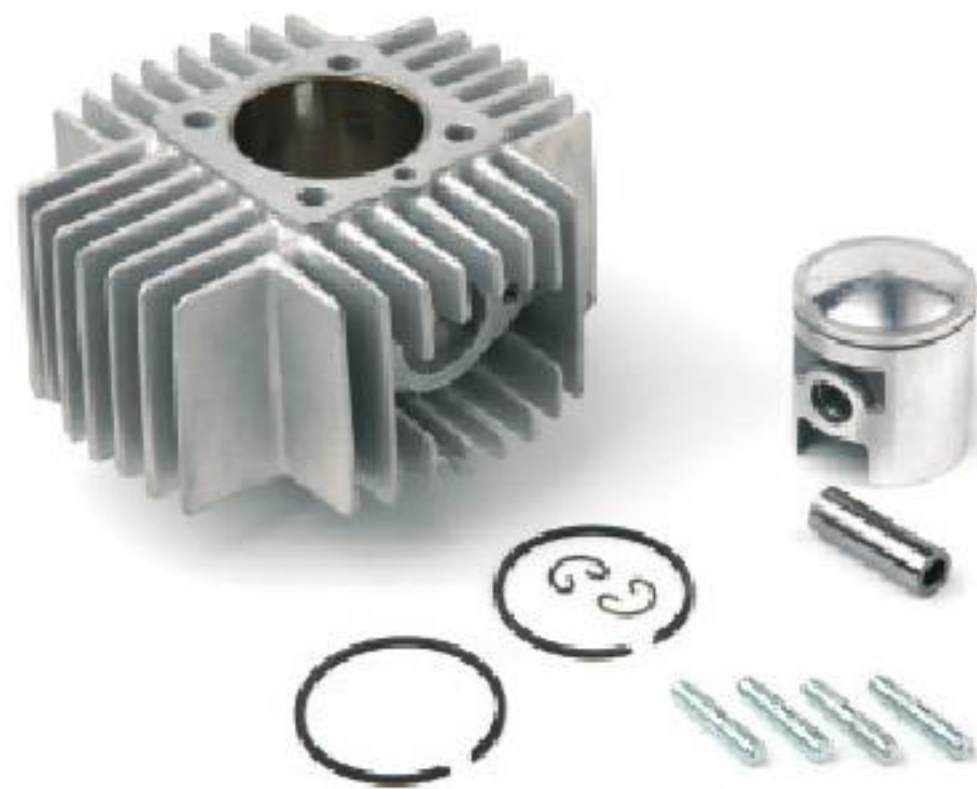

MOD. ADAPTABLE

PUCH Automático X20, Maxi Aleta pequeña, X30.



Ø 38	48,8 cm ³	02030138	06030138	11030138	14030138
Ø 44	65,4 cm ³	02030844	06030844	11030844	14030844
Ø 45	68,4 cm ³	02030345	06030345	11030345	14030345
76 Ø 38	48,8 cm ³	02030939	06030939	11030939	14030939

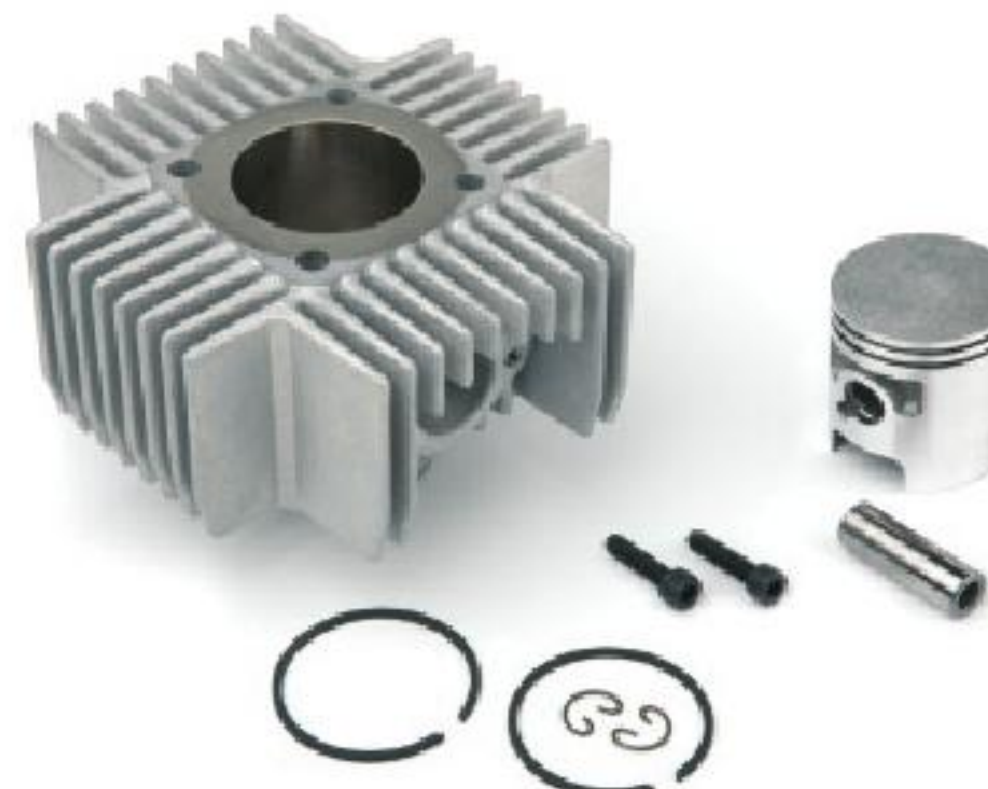

MOD. ADAPTABLE

- BIMOTOR** Contry 50.
- CALELLA** Colcar 50.
- GHIARONI** New deal 50.
- LEM** Malibu Lux 50.
- MALAGUTI** New dribbling.
- MONDIAL** S150.
- MORINI** M1, M101, M1ES 50, M1K.
- MOTOESA** Mini 50.
- PUCH** Maxi España.
- SACOM** Cathy 50, CR1-S 50.
- SIS** Morini 50.
- SUZUKI** Maxi.
- TESTI** 10 50.



Ø 43,5	58,8 cm ³	020306435	060306435	110306435	140306435
--------	----------------------	-----------	-----------	-----------	-----------

Cilindro de aluminio con recubrimiento de níquel silicio.
Cylindre en aluminium et revêtement de nickel carbure de silice.
Aluminium cylinder with nickel silicon carbide plating.

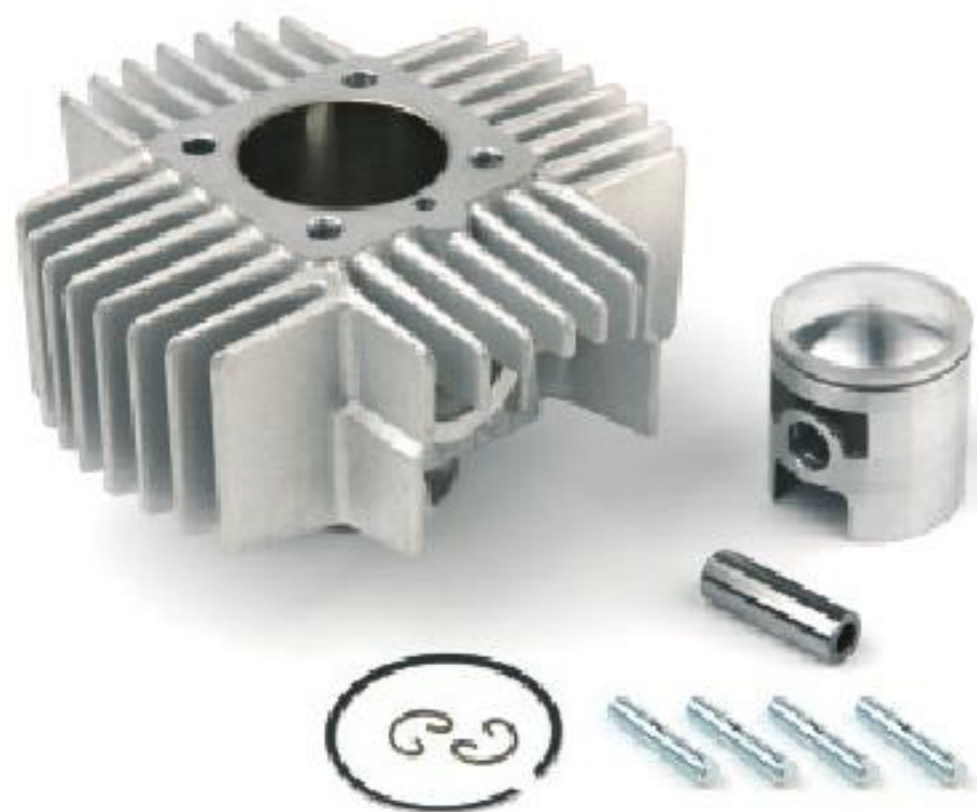

MOD. ADAPTABLE

PUCH Automático Maxi Aleta Grande.



Ø 38	48,8 cm ³	02031238	06031238	11031238	14031238
Ø 45	68,4 cm ³	02030745	06030745	11030745	14030745
76 Ø 38	48,8 cm ³	02031138	06031138	11031138	14031138



MOD. ADAPTABLE

TOMOS A35 Limited, A35 Quatro, A38B, S25/2 Limited, S25/2 Luxe.



Ø 38	49,5 cm ³	02210138	06210138	11210138	14210138
Ø 44	63,7 cm ³	02210244	06210244	11210244	14210244



MOD. ADAPTABLE
PEUGEOT Fox 50.



MOD. ADAPTABLE
TOMOS A55, Arrow, Revival TS, Streetmate.

Ø 40 49,3 cm³      
02024640 06024640 11024640 14024640

Ø 44 63,7 cm³      
01210444 02210444 04210444 06210444 11210444 14210444



MOD. ADAPTABLE
PUCH Maxi.



MOD. ADAPTABLE
HERCULES
SACHS 504,505.

Ø 46 63,2 cm³      
01031446 02031446 04031446 06031446 11031446 14031446

Ø 43,5 62,4 cm³      
012002435 042002435 062002435 112002435 142002435



Cilindro de hierro
Iron cylinder
Cylindre en fonte



MOD. ADAPTABLE

BULTACO Astro, Lobito.
DERBI DRD, GPR RACING, R Racer, Senda 50, SM Supermotard.
GILERA GSM, Zulu.



MOD. ADAPTABLE

APRILIA Alle50, Extrem, Red rose, RS50, RX50.
MBK X Limit, X Power.
MINARELLI AM 345i6, AM 6 EU1.
MOTRHISPANIA Furia 50, Racing RX 50, Supermotard.
PEUGEOT Supermotard, Trail, XP6, XR6.
RIEJU MRK, ES1 RR6 50, SMX.
SHERCO HRD Enduro, Supermotard.
YAMAHA DT 50 Supermotard, Tunderkit, TZR 50.

Ø	Stroke / Carrera	cm³					
39,9	40	50	010890399		040890399	060890399	110890399 140890399
47	40	69,4	01089147		04089147	06089147	11089147 14089147

Ø	Stroke / Carrera	cm³					
40,3	39	49,7	H011381403	H041381403	H061381403	H111381403	H141381403
48	39	70,5	H01138248	H04138248	H06138248	H11138248	H14138248



MOD. ADAPTABLE

ENGINE PIAGGIO.
DERBI 2006, Senda, SM DRD, Pro, SM, DR Racing.
GILERA RCR, SMT.



MOD. ADAPTABLE

APRILIA Guilliver, Rally Scarabeo, Sonic, SR94, SR.
ATALA Corosello.
BENELLI 491 LTG, K2 Air, Namura, Pepe.
BETA CArk, Chrono, Tempo, Quadra.
BSV AX, GZ.
CPI Euro1, Hussar.
MALAGUTI Centro, Clark, F10, F12, Phantom 50, Yesterday.
MBK Evolis Fizz, Flipper, Forte, Hot Champ, Ovetto, Sorriso.
MINARELLI C Y50.
MOTRON Syncro, Thunder S.
PGO Big Max.
RIEJU First 50 Windi.
YAMAHA Axis, Breeze, Jog 50, JogZ, Neos, Why, Zest.

Ø	Stroke / Carrera	cm³					
39,9	40	50	H010892399	H040892399	H060892399	H110892399	H140892399
47	40	69,4	H01089347	H04089347	H06089347	H11089347	H14089347

Ø	Stroke / Carrera	cm³					
40	39,2	49,2	H02138340	H06138340	H11138340	H14138340	
47	39,2	68	H01138447	H04138447	H06138447	H11138447	H14138447



MOD. ADAPTABLE

APRILIA Area, Gulliver, Ralli LC, Sonic, SR50, Stealth LC..
BENELLI 491 Sport Racing, K2 LC..
BETA ARK 1c, Elkon 50.
ITALJET Dragster.
MALAGUTI F12, F15, Firefox, Phantom LC.
MBK Nitro 50.
RIEJU First 50 LC.
YAMAHA Aerox 50.

Ø	Stroke / Carrera	cm³					
40	39,2	49,2		H02073840	H06073840	H11073840	H14073840
47	39,2	68	H01073947		H06073947	H11073947	H14073947



MOD. ADAPTABLE

APRILIA Amico, Business Gudman, LK LX Sport, SR.
ITALJET Ascort, Astra, Bazoka, Pista Reporter.
LEM Flash, Ghibli, SS1, Tornado.
MBK Booster, Rocket, Sorriso, Stunt, Target.
MINARELLI CW50.
YAMAHA BWS, CT50, CR50Z, Slinder, SP Y50, Zuma.

Ø	Stroke / Carrera	cm³					
40	39,2	49,2		H02138540	H06138540	H11138540	H14138540
47	39,2	68	H01138647		H06138647	H11138647	H14138647



Cigüeñas
Vilebrequins
Crankshaft





MOD. ADAPTABLE



APRILIA Alle 50, Extrema, Red rose, RS 50, RX 50.
MBK X Limit, X Power.
MINARELLI AM 345/6, AM 6 EU1.
MOTORHISPANIA Furia 50, Racing RX 50, Supermotard.
PEUGEOT Supermotard, Trail, XP6, XR6.
RIEJU MRK, RS1, RR6 50, SMX.
SHERCO HRD Enduro, Supermotard.
YAMAHA DT 50 Supermotard, Thunderkit, TZR 50.

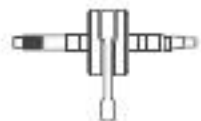

MOD. ADAPTABLE

ENGINE PIAGGIO.
DERBI Mod. 2006 SENDA, SM, DRD, PRO, SM, DRD Racing.
GILERA RCR, SMT.

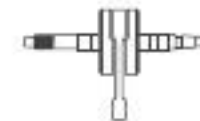
Pin / Bul.	Stroke / Carrera			
12	39	31134950	32134950	33134950
12	45	31137350	32137350	33137350

Pin / Bul.	Stroke / Carrera			
12	40	31085950	32085950	33085950
12	45	31087550	32087550	33087550



MOD. ADAPTABLE



BULTACO Astro, Lobito.
DERBI DRD, GPR Racing, R Racer, Senda 50, SM Supermotard.
GILERA GSM, Zulú.

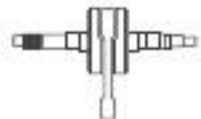

MOD. ADAPTABLE

APRILIA Area, Gulliver, Ralli LC, Sonic, SR 50, Stealth LC.
BENELLI 491 Sport Racing, K2 LC.
BETA ARK LC, Eikon 50.
ITALJET Dragster.
MALAGUTI F12, F15, Firefox, Phantom LC.
MBK Nitro 50.
RIEJU First 50 LC.
YAMAHA Aerox 50.

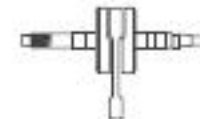
Pin / Bul.	Stroke / Carrera			
12	40	31083750	32083750	33083750
12	45	31087650	32087650	33087650

Pin / Bul.	Stroke / Carrera			
10	39,2	31071140	32071140	33071140
12	39,2	31073450	32073450	33073450
12	45	31073350	32073350	33073350



MOD. ADAPTABLE

GILERA Runner 50.
PIAGGIO Extrem, NRG, NRG Mc2,
 NTT, Quartz, Zip, Zip Sp2000.

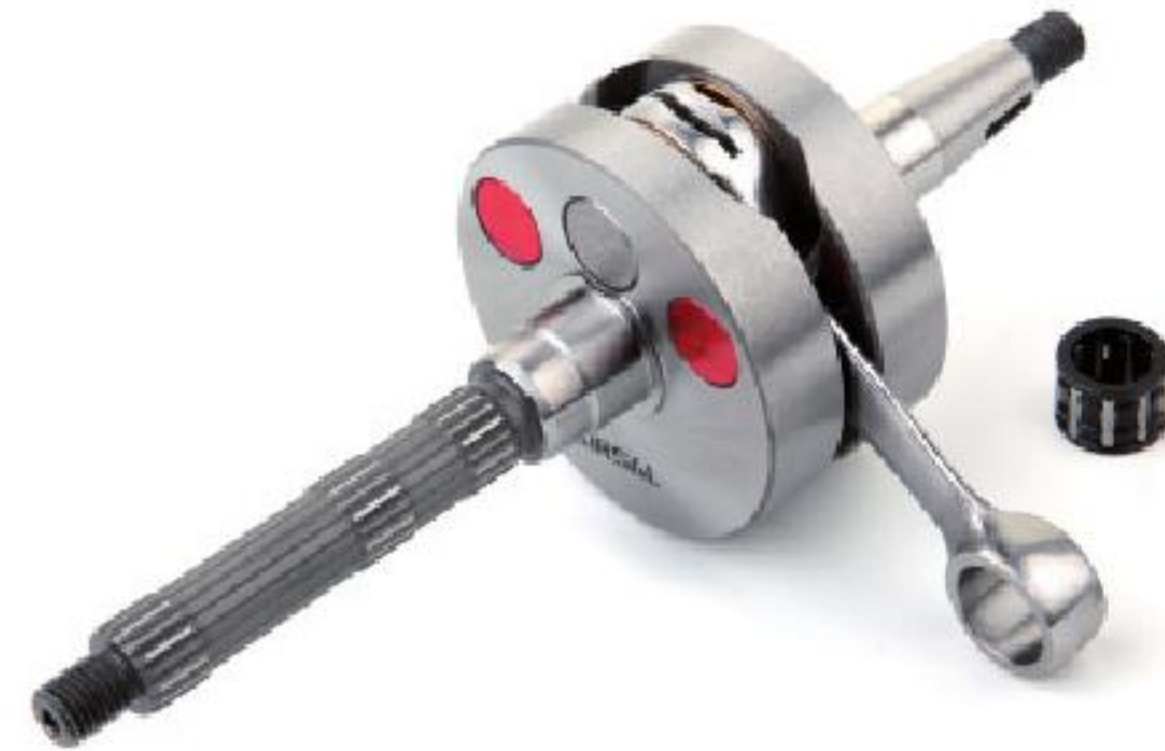

MOD. ADAPTABLE

GILERA Easy Moving, Stalker 50, Storm,
 Typhoon.
PIAGGIO Extrem, Free 50, Liberty, Sfera 50,
 Storm, Typhoon, Vespa ET2, Zip.

Pin / Bul. Stroke / Carrera

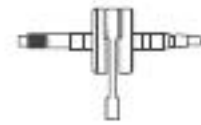

12	39,3	31064450	32064450	33064450
12	44	31064350	32064350	33064350

Pin / Bul. Stroke / Carrera

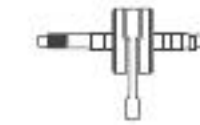

12	39,3	310617476	320617476	330617476
----	------	-----------	-----------	-----------



MOD. ADAPTABLE

APRILIA Gulliver, Rally, Scarabeo, Sonic,
 SR94, SR www.
ATALA Corosello.
BENELLI 491 GT, K2 air, Namur, Pepe.
BETA Ark, Chrono, Tempo, Quadra.
BSV AX, GZ.
CPI Euro 1, Hussar.
MALAGUTI Centro, Ciak, F10, F12,
 Phantom 50, Yesterday.
MBK Evolis, Fizz, Flipper, Forte, Hot Champ,
 Ovetto, Sorriso.
MINARELLI CY50.
MOTRON Syncro, Thunder S.
PGO Big Max.
RIEJU First 50, Windi.
YAMAHA Axis, Breeze, Jog 50, Jag Z, Neos, Why,
 Zest.



MOD. ADAPTABLE

MBK AV10, AV-51.

Pin / Bul. Stroke / Carrera

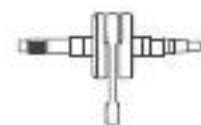

10	39,2	311316476	321316476	331316476
----	------	-----------	-----------	-----------

Pin / Bul. Stroke / Carrera

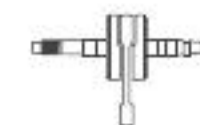

13	41,8	31140639	32140639	33140639
76 13	41,8	31140739	32140739	33140739



Kit variador / Kit engranajes
Kit variateur / Kit engrenajes
Variator kit / Gears kit



MOD. ADAPTABLE

APRILIA Area, Gulliver, Ralli LC, Sonic, SR50, Stealth LC.
BENELLI 491 Sport RAcing, K2 LC.
BETA ARK LC Eikon 50.
ITALJET Dragster.
MALAGUTI F12, F15, Firefox, Phantom LC.
MBK Nitro 50.
RIEJU First 50 LC.
YAMAHA Aerox 50.



MOD. ADAPTABLE

YAMAHA X MAX125.

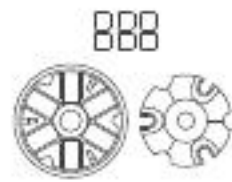

27073350

888

24073350



28073350



35073350

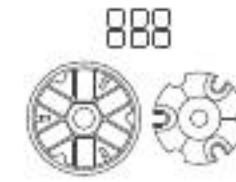

27125852

888

24125852



28125852



MOD. ADAPTABLE

HONDA S-Wing 125-150, PS 125-150, Dylan 125-150, Phantheon 125i-150i, @ 125i-150i, Scoopy SH125-150.

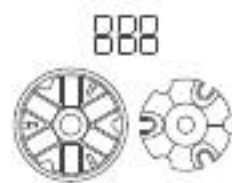

270462524

888

240462524



280462524

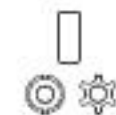

HONDA	S-Wing 125, PS 125i, Dylan 125, Phantheon 125i, @ 125i.	360462524
HONDA	S-Wing 150, PS 150i, Dylan 150, Phantheon 150i, @ 125i.	36046458
HONDA	Scoopy SH 125i, Scoopy SH 150i.	36046524

CONDICIONES GENERALES PARA LA REPARACIÓN

Nuestra empresa únicamente recupera cilindros de aluminio sin camisa de hierro.

DIAMÈTRE	38-45	46-53	54-56	57-60	61-70	71-80	81-90	91-+
PRIX PUBLIC	103€	111€	129€	137€	153€	176€	189€	212€

El precio de esta tarifa incluye:

- Eliminar el recubrimiento dañado.
- Soldar el cilindro, si el desperfecto lo precisa, y retocar a mano las ventanas.
- Aplicar una nueva capa de Scanimet®.
- Lapear el cilindro dejando la tolerancia según precise el pistón que se tenga que montar.

No incluye:

- Los gastos de transporte.
- El desmontado de piezas: El cilindro debe sernos entregado completamente desmontado (sin espárragos, válvula de escape, caja de láminas, etc.).

En el caso de llegar con alguna pieza montada se facturaría un recargo adicional de:

- 12 € neto por desmontar los tornillos del cilindro.
- 20 € neto por desmontar la válvula del escape.

Nota importante: de tener que desmontar alguna pieza del cilindro, AIRSAL no se hace responsable si esta se rompe en el proceso de desmontado, corriendo a cargo del cliente la sustitución de la misma. Asimismo AIRSAL no devolverá montada ninguna de las piezas que se hayan tenido que desmontar para poder proceder la recuperación del cilindro.

Aro de bronce: Los cilindros con detonaciones se repararan habitualmente mediante soldadura del cilindro ya incluido en el precio. Si el cliente prefiere que se haga aplicando un aro de bronce deberá especificarse por escrito junto al cilindro. Esto supondrá un importe adicional de 40 € neto.

Pistón: Junto con el cilindro dañado, rogamos nos remitan el pistón nuevo que vaya a montar en este cilindro. Esto nos permite ajustar la tolerancia cilindro / pistón.

Si el cliente desea una tolerancia diferente a la aconsejada por el fabricante de la motocicleta, rogamos lo especifique por escrito y lo remita junto con el cilindro.

Forma de pago: mediante transferencia bancaria o contra reembolso.

CONDITIONS GÉNÉRALES DE RÉPARATION

Notre entreprise ne récupère que les cylindres en aluminium sans chemise en fonte.

DIAMÈTRE	38-45	46-53	54-56	57-60	61-70	71-80	81-90	91-+
PRIX PUBLIC	103€	111€	129€	137€	153€	176€	189€	212€

Les montants de ce tarif incluent ce qui suit:

- Eliminer le revêtement d'origine.
- Souder le cylindre, si le dommage l'exige.
- Appliquer une nouvelle couche de Scanimet®.
- Roder le cylindre en prévoyant la tolérance exigée par le piston qu'il faudra monter.

Ils n'incluent pas:

- Les frais de transport.
- Le démontage des pièces: le cylindre doit nous être remis complètement démonté (sans goujons, soupape d'échappement, boîte à clapet, etc.).

Si il nous est envoyé avec une pièce montée, il vous sera facturé une majoration supplémentaire de:

- 12 € net pour le démontage des vis du cylindre.
- 20 € net pour le démontage de la soupape d'échappement.

Note importante: Si une pièce doit être démontée sur le cylindre, AIRSAL décline toute responsabilité si celle-ci se casse pendant le démontage, et son remplacement sera à la charge du client. De même, AIRSAL ne retournera montée aucune des pièces qui auront dû être démontées pour pouvoir procéder à la récupération du cylindre.

Bague en bronze: Les cylindres à détonations sont habituellement réparés par soudure du cylindre, déjà incluse dans le prix. Si le client préfère qu'il y soit procédé en utilisant une bague en bronze, il devra le préciser par écrit lors de l'envoi du cylindre. Cela représentera un montant supplémentaire de 40€ Net.

Piston: En même temps que le cylindre endommagé, nous vous prions de nous envoyer le nouveau piston à monter dans ce cylindre. Cela nous permettra de régler la tolérance cylindre / piston.

Si le client désire une tolérance autre que celle conseillée par le fabricant de la moto, nous vous prions de nous la préciser par écrit lors de l'envoi du cylindre.

Mode de paiement: par virement bancaire ou contre remboursement.

GENERAL CONDITIONS FOR REPAIR

Our company only repairs **aluminium cylinders** that do not have a cast- iron sleeve.

DIAMÈTRE	38-45	46-53	54-56	57-60	61-70	71-80	81-90	91-+
PRIX PUBLIC	103€	111€	129€	137€	153€	176€	189€	212€

This price includes:

- Removal of the original coating.
- Weld the cylinder if required.
- Apply a new coat of Scanimet®.
- Polishing the cylinder within tolerance as required by the piston that is to be installed.

Does not include:

- Shipping costs.
- Removal of parts: The cylinder must be delivered to us completely disassembled (without bolts, exhaust valve, reed valve, etc.).

If the cylinder is delivered with attached parts, an additional charge will be incurred:

- 12 € for removing bolts from the cylinder.
- 20 € for removing the exhaust valve.

Important Note: If any part must be removed from the cylinder, AIRSAL will not be held liable if this part breaks during the removal process and the cost of replacing said part will be incurred by the customer. Also, AIRSAL will not re-assemble any part that had to be removed in order to repair the cylinder.

Brass ring: Cylinders with **detonation** will normally be repaired by welding the cylinder, which is already included in the price. If the customer prefers this repair be carried out using a brass ring, he must specify this in writing and send it with the cylinder. An additional 40€ will be charged for this repair.

Piston: Along with the damaged cylinder, please send the new piston that is to be assembled with the cylinder. This allows us to adjust the cylinder/piston tolerance.

If the customer desires a tolerance other than the one recommended by the motorcycle manufacturer, please specify this in writing and send it with the cylinder.

Payment method: By way of bank transfer or cash on delivery.